

Product Overview
www.skydome.com.au

AUS - JULY 2008 - VER 1.3



Contact Us

13 24 24
(Local Call Cost)

www.skydome.com.au
sales@skydome.com.au

NSW Showroom

77 Queens Road
FIVE DOCK, NSW 2046
Ph: +61 2 9745 1522
Fax: +61 2 9744 1267

QLD Showroom

Unit 2, 11 Eileen Street
UNDERWOOD, QLD 4119
Ph: +61 7 3299 4377
Fax: +61 7 3208 0701



HIA members
the best in the business



Our AWA membership
is your guarantee
of performance

NEW! SKYDOME®

Press Formed into CORRUGATED Profile

The Skydome® skylight remains the number one choice when it comes to delivering natural light to any area of the home. Installing a Skydome® provides the freedom to design any room away from the exterior walls with the ease of knowing that you can provide natural light and ventilation in a cost and energy efficient way.

A Skydome® skylight will suit most types of roofing profiles and now comes offered in two unique flashing styles; traditional one-piece flashing and **NEW** press formed flashing pre-fitted into corrugated profile.

Tested to Australian Standards (AS4285), the Skydome® skylight provides protection from harmful UV rays (99% UV Skyguard™) and are guaranteed not to leak.

Designed with an emphasis on Australian construction methodology and the harsh Australian climate, the Skydome® skylight system will make your rooms come alive!

13 14 24

sales@skydome.com.au

SKYDOME®

NEW Press Formed Skydome® for Corrugated Roofs

The NEW press formed Skydome® for corrugated roof profiles, closes off the corrugations perfectly. This reduces the usage of sealants resulting in a perfect seal.

The benefit of the rear in-built soaker tray eliminates pooling behind the skylight, which on low pitched roofs helps reduce corrosion, maintaining maximum service life.

Skydome® has been established since 1976 and is proudly Australian owned; your guarantee of quality workmanship and materials.



- ☑ Guaranteed leakproof to AS4285/1995
- ☑ Can be colour matched to the roof
- ☑ 7 year manufacturer's warranty
- ☑ Pre-fitted into corrugated profile
- ☑ Quick and easy installation
- ☑ In-built soaker tray
- ☑ Full accessory range
- ☑ Vent or non-vent option available
- ☑ Full compatibility with Zinalume® and Colorbond®

PRESSED CORRUGATED SELECTION CHART				
PRODUCT CODE	INTERNAL OPENING mm		LIGHT AREA M ²	VENT x AREA M ²
	WIDTH	LENGTH		
CSDP 500	500	500	0.250	0.088
CSDP 5/8	500	800	0.400	0.112
CSDP 5/12	500	1200	0.600	0.144
CSDP 600	600	600	0.360	0.104
CSDP 6/8	600	800	0.480	0.120
CSDP 6/12	600	1200	0.720	0.152
CSDP 800	800	800	0.640	0.136
CSDP 8/12	800	1200	0.960	0.168



The daylighting experts!

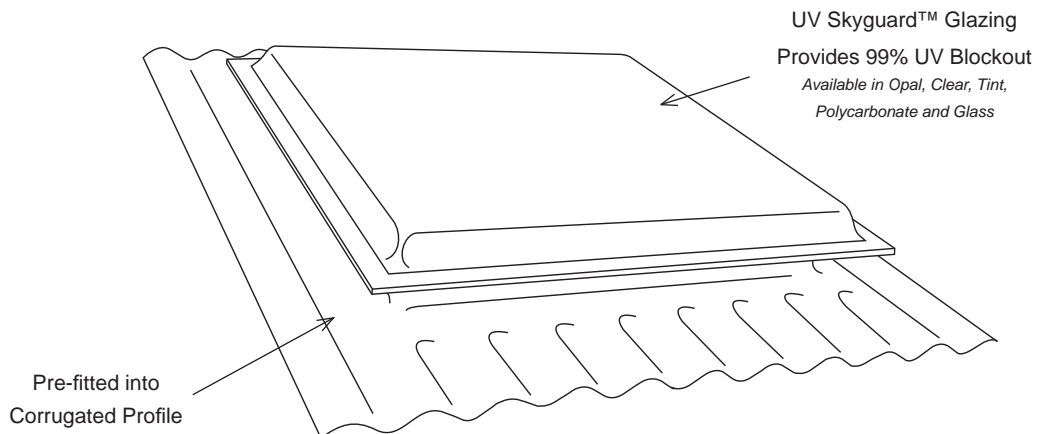

Skydome® is a registered trademark of Skydome® Skylight Systems Pty. Ltd. (ABN 52 001 918 494). Zinalume® and Colorbond® are registered trademarks of BlueScope Steel Limited. Profile offered is manufactured to match Custom Orb and similar profiled. All images and text contained in this brochure are the sole property of Skydome® Skylight Systems Pty. Ltd. and are reserved under © copyright law. It is the responsibility of the user to ensure that the selected skylight system complies with relevant building codes and authorities requirements. Skydome® Skylight Systems Pty. Ltd. reserves the right to improve or modify these products at any time.

The product described herein is protected by one or more of the following; Australian Patent No. 688444, 686419 and 712432; Australian Registered Design No. 127024 and 118780.